



Volvo Trucks. Driving Progress

VOLVO FMX

PRODUCT GUIDE - EURO 3-5





A new standard in construction.

Come heavy loads, come challenging terrain – the Volvo FMX has been designed to handle tougher conditions than ever.

But rugged strength only takes you so far. That's why it also comes with a host of clever features that allow you to get the job done quicker, safer, more comfortably and with better operating economy. And it comes in more configurations than ever, so you can always be sure to find one that perfectly matches your needs.

Discover how the Volvo FMX can set a new standard for your business.

OVERVIEW

A closer look at the Volvo FMX.

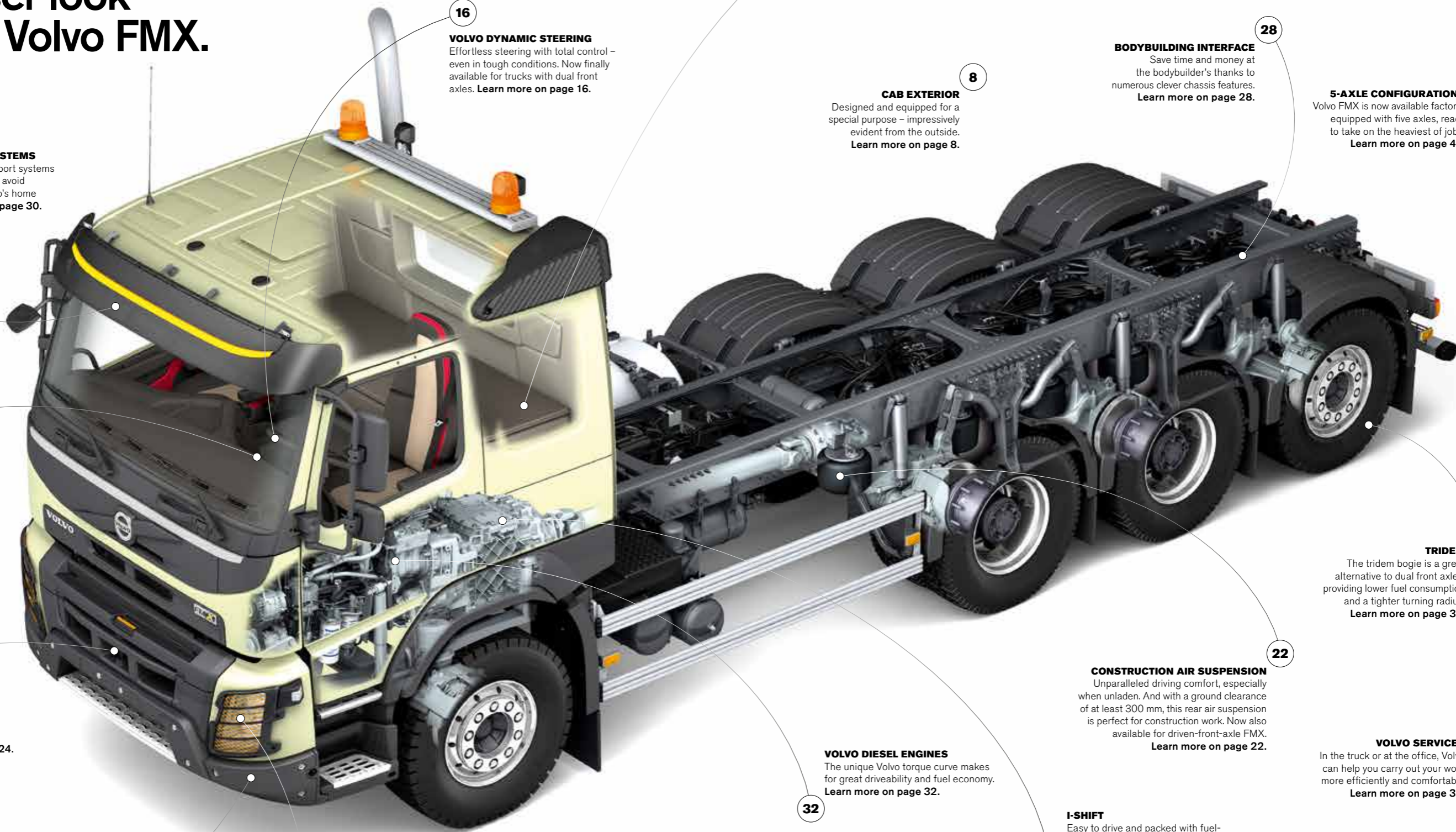

30 DRIVER SUPPORT SYSTEMS
Our advanced driver support systems efficiently help the driver avoid accidents. Safety is Volvo's home ground. [Learn more on page 30.](#)

18 DRIVER INTERFACE
The instrument cluster and the new integrated system for services and infotainment offers an industry leading driver interface. [Learn more on page 18.](#)

24 TOWING DEVICE
A towing device that is worthy of its name. [Learn more on page 24.](#)

20 THE LOWER FRONT
It's not just a bumper that meets the eye. It's a complete system that can affect your uptime. [Learn more on page 20.](#)

36 HEADLIGHTS
The headlights may well be the best in the industry. [Learn more on page 36.](#)

16 VOLVO DYNAMIC STEERING
Effortless steering with total control – even in tough conditions. Now finally available for trucks with dual front axles. [Learn more on page 16.](#)

8 CAB EXTERIOR
Designed and equipped for a special purpose – impressively evident from the outside. [Learn more on page 8.](#)

14 CAB INTERIOR
Spacious and filled with features that support the driver and make the working day more enjoyable. [Learn more on page 14.](#)

32 VOLVO DIESEL ENGINES
The unique Volvo torque curve makes for great driveability and fuel economy. [Learn more on page 32.](#)

6 AUTOMATIC TRACTION CONTROL
Great traction, driveability and fuel economy. All driven front-axle Volvo FMX now come with ATC as standard. [Learn more on page 6.](#)

10 I-SHIFT
Easy to drive and packed with fuel-saving software. Now available for tougher conditions than ever, and with the option of crawler gears. [Learn more on pages 10-13.](#)

22 CONSTRUCTION AIR SUSPENSION
Unparalleled driving comfort, especially when unladen. And with a ground clearance of at least 300 mm, this rear air suspension is perfect for construction work. Now also available for driven-front-axle FMX. [Learn more on page 22.](#)

38 VOLVO SERVICES
In the truck or at the office, Volvo can help you carry out your work more efficiently and comfortably. [Learn more on page 38.](#)

44 ACCESSORIES
Tailor your truck for your assignments – and make it more efficient for the work you do. [Learn more on page 44.](#)

28 BODYBUILDING INTERFACE
Save time and money at the bodybuilder's thanks to numerous clever chassis features. [Learn more on page 28.](#)

40 5-AXLE CONFIGURATIONS
Volvo FMX is now available factory-equipped with five axles, ready to take on the heaviest of jobs. [Learn more on page 40.](#)

34 TRIDEM
The tridem bogie is a great alternative to dual front axles, providing lower fuel consumption and a tighter turning radius. [Learn more on page 34.](#)

26 TANDEM AXLE LIFT
Only use the extra drive axle when you need it. Tandem Axle Lift reduces your fuel consumption, tightens your turning radius and improves your traction. [Learn more on page 26.](#)

VIEW SOME OF THE SPECS ON PAGES 42-43

All the traction you need.

But only when you need it.



Lower fuel consumption, less wear and better manoeuvrability – automatically. Every driven-front-axle Volvo FMX now comes as standard with the revolutionary Automatic Traction Control.

2%

Let it roll. And save up to 2% fuel.

You'd be surprised to learn how seldom you actually need the driven front axle to be engaged, even in the toughest of terrains. A test carried out in a desert (and that's about as sandy as road conditions get), showed that the frontwheel drive could be disengaged more than a staggering 95% of the time. ATC takes advantage of this. By automatically disengaging the front axle when it's not needed, it can reduce your fuel consumption by up to 2% (based on a regional haul driving cycle).



Don't worry. It's all well protected.

The Volvo FMX chassis has been designed to protect all vital parts from damage. The parallel rods and link rods are all placed in line with the axle, inside the axle-casing envelope. The brake chambers and fuel tanks are also well protected. Furthermore, the driven front axle has the same position as the non-driven axle, which provides an approach angle of 28° (with 13R22.5 tyres), a benefit when climbing steep gradients. The driven front axle is now also available with rear air suspension, providing a ground clearance of 300 mm.



No compromise on driving. No compromise on steering.

Without a driven front axle, you may risk getting stuck. But when it's engaged, it inevitably impairs the manoeuvrability of the truck. This is where ATC, unlike permanent systems, offers the best of two worlds. When the driven front axle is engaged, you have all the traction you need, and when it's disengaged (which it is most of the time), the grip of the front tyres can be dedicated to steering, greatly improving the manoeuvrability of your truck.



Maximum traction. Without delay.

The system is very fast and reliable. If the sensors in the wheels detect any loss of traction, the dog clutch to the front axle engages automatically in half a second. It then stays engaged until you release the gas pedal and have sufficient traction again. ATC requires no driver interaction – it just works. However, a dashboard switch provides the possibility to manually engage the front axle, or, when the driving conditions get extremely rough, engage all the diff locks.

CAB EXTERIOR

How to recognise a true construction truck.

The robust design of the Volvo FMX is clearly different from all other trucks. Here are some details that make it stand out. Details that make a great difference for the drivers' daily work.



Entry step.

A low and foldable step makes it easier to enter trucks with a high chassis. All three steps have an anti-skid design. The extra light in the door aids safe entry when it gets dark.



Ladder.

The ladder and the rail make it easy to climb up and inspect the load in the bay. The steps have an anti-skid design.



Mirrors.

Robust rear-view mirrors with sturdy mountings, that withstand rough treatment. Slim mirror arms for good forward vision.



High air intake.

High air intake contributes to a good backwards view when reversing. It's got high air throughput and is well protected from dust.



The Volvo iron mark.

Moved up, closer to the driver. Big and mighty, just like the truck. Be proud of driving a Volvo.



Footstep in front.

The whole sturdy lower front can work as a ladder. Just climb up on it. And for even better access when cleaning the windscreen, there's the option of an extra ladder to put on the front bumper.



Forget the gearbox. Just drive.



Eases your mind and your left foot.

Driving I-Shift is a real pleasure. Without the clutch pedal, you can safely sit back and concentrate on the other two. I-Shift uses its built-in intelligence to quickly and automatically choose the right gear at all times. And the software provides shifting skills that are impossible for even the best of drivers to match. Still, if you want to get more involved, you can. The buttons on the shift selector allow you to step in and shift gear manually.

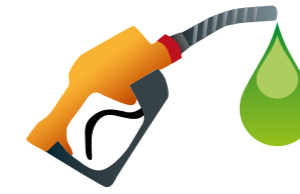

**Let I-Shift save you fuel.
The money will roll right in.**

I-Shift is designed to save fuel. First of all, the internal losses are low – actually lower than on manual gearboxes. But it's the electronics that really make the difference. When driving in Economy mode, every gear change is timed precisely, to let the engine work at its most efficient rpm range. And then there's I-Roll. It's a unique feature used when driving downhill, automatically disengaging the engine to make use of the truck's momentum instead of fuel. The result? Up to 2% lower fuel consumption.



**The reinforced I-Shift.
For severe duty applications.**

If you drive in extremely tough conditions, you will appreciate the reinforced I-Shift. It has been designed exclusively for environments where you frequently climb or descend gradients of above 10%, or drive in extremely rough terrain. This means that I-Shift is now available for conditions where a manual gearbox or the automatic Powertronic used to be the only options.

How would you like your I-Shift?

The software makes it possible to tailor I-Shift to your driving conditions. Choose from four add-on packages: Long Haul (with or without I-See)* for efficient highway driving, Distribution with smart functions for close-quarter manoeuvring, Construction that handles tougher road conditions and Heavy Duty Transport (with or without I-See*) optimising I-Shift for gross combination weights above 85 tonnes. 🚚



How it works.

It may seem strange. Beneath the surface of I-Shift, the archetype of modern transmissions hides an old-school unsynchronised manual gearbox. (Hence the compact design and low internal losses.) But of course there's more to I-Shift than that. The secret lies in the intelligent electronic control unit. It's responsible for controlling the pneumatic system that handles the clutch and shifts. By constantly receiving information about vehicle speed, acceleration, weight, road grade, torque demand and more, it can carry out every shift with extreme precision. It also communicates closely with the engine, which in turn adjusts revs and engine-brake effect for fast and comfortable shifting.



**NOW SLOWER
THAN EVER.
TURN THE PAGE
TO LEARN MORE.**

🚚 Also available as an accessory. *I-See is only available on Euro 5 and Euro 6 markets.

The fastest way to productivity?

Slow down.

I-Shift just got even more versatile and easy to drive. The automated gearbox is now available with the choice of one or two crawler gears, plus the additional option of extra reverse gears.



Start wherever you want.

If you transport heavy loads, you know that starting from a standstill can sometimes be difficult, especially in hilly terrain or poor road conditions. Ultimately, you may have to unload the cargo or even request towing, which has devastating effects on your uptime and productivity. Equip your FMX with crawler gears and this will be a worry of the past. Your startability is dramatically improved, and the strain on the clutch is reduced by up to 75 percent, saving you from unnecessary repairs.



Crawl slow, run lean.

Can crawler gears really help boost your fuel economy? Sure. Because previously, you often had to be willing to sacrifice fuel economy for startability. But thanks to the crawler gears, we can now specify your truck with a faster rear axle ratio, allowing you to stay on cruising speed at much lower revs when you're driving on decent roads. This lowers your fuel consumption by up to a couple of percent.



Say yes to more jobs.

Crawler gears adds to the versatility of the truck, letting you use the same truck for a host of different driving conditions and assignments. Drive both on-road and off-road? Need to transport extreme loads? Work at high altitudes? Special low-speed applications? No problem.

37:1

Perfect control in any direction.

Low-speed manoeuvring is one of the most challenging aspects of the job. Thanks to a transmission ratio of up to 32:1 (and up to 37:1 in reverse), the crawler gears let you drive slower than ever – half the speed compared to a regular I-Shift. You always have total control, making it easy to park with precision when you're about to load or unload your cargo, and to avoid accidents that can ruin your day and your productivity.

SLIM GEARS

The crawler gear module only adds 120 mm to the length and 48 kg to the weight of I-Shift.

CAB INTERIOR

It's dirty out there. Yet clean and homely in here.



Easier steering wheel adjustment. More knee space.

We adjusted the adjustment pedal for the steering wheel and modified the steering column to create more space for your knees.



Everything at your fingertips.

Easy-to-use navigation and fleet management. Improved communication and increased safety. Enhanced quality audio entertainment. Volvo's integrated system for services and infotainment brings together everything you need on the 7-inch touch screen. Learn more on [page 18](#).



Sound system.

The sound system includes everything you need to enhance your in-cab experience. Access to streaming media services such as Spotify, Deezer and TuneIn. DAB/DAB+ (Digital Audio Broadcasting) as option. [+](#)



Plenty of room for your gear.

The spacious front, under-bunk (option), rear and exterior storages can be tailored to your needs, and are accompanied by plenty of convenient compartments for smaller items.



Advanced interior lighting.

The energy-efficient and powerful light sources make for fantastic in-cab lighting. All are easily controlled in three pre-set steps or with the dimmer. When driving in the dark – switch to the red lights to preserve your night vision.



Electronic Climate Control.

The electronic climate control makes sure you always have a comfortable climate in the cab. Just set your preferred temperature.



Bed for rest and sleep.

Don't compromise on sleep quality just because you spend your night in the cab. The lower bed is 70 cm wide and features 16 cm pocket springs and a choice of three different firmness levels.



Stay in bed.

The sleeper panel lets you control the interior lights, alarm clock, parking heater, audio system, windows and locks. All without leaving the bunk.

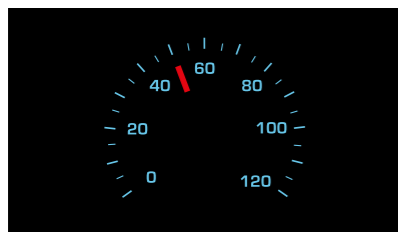

Night mode.

A standard safety feature that allows you to turn off all backlights in the instrument cluster, except for the speedometer. You won't be distracted by irrelevant lights. This makes it safer to drive at night – or to connect the trailer when visibility is poor. However, if a warning alert occurs, it will show up on the panel.



All at your thumb tips.

Buttons for cruise control, audio, phone and what's in the information displays, allow you to keep a tight grip on the wheel.



Raven colour.

Raven is the colour of the dashboard. It is especially developed for the construction environment, because this colour is less sensitive to dirt.



Room for work.

A comfortable driver's seat, splendid visibility and lots of space make your work more enjoyable – and safer. A good overview of the dashboard, plus every button and lever within easy reach makes driving easier.



Clean water anywhere.

If you want fresh water, you don't have to go far. The exterior compartment holds a 7-litre tank equipped with a tap. [+](#)



Electric parking brake.

The electrically controlled parking brake is handled with an easy-access dashboard switch. Automatically engaged at key-off, and – with a little help from EBS – automatically released when taking off.



Electronic remote key.

It's more than a key. Lock or unlock from a distance. Turn on the lights to approach the cab safely. And if you're feeling threatened, just push the panic button to blast the horn. [+](#)



A great position to be in.

Every driver knows the value of a good seat. The one in the Volvo FMX can be adjusted 20 cm fore-aft and 10 cm vertically. And it features a cushion that's more comfortable than ever.



Ergonomics first.

The gently curved dash not only looks appealing. It's designed for an ergonomic and comfortable driving position with all controls, instruments and storages within easy reach.



Built in bird bath.

The bird bath is built in on the top of the dashboard. It's a practical place to keep small odds and ends and it's even got a penholder.



Parking heater.

Waiting out in the cold when loading, un-loading or having a rest on the roadside? With the parking heater you can always keep a comfortable climate inside the cab. [+](#)



Room for alcolock.

Alcohol doesn't belong in traffic. That's why the alcolock does. Factory fit it to your Volvo FMX, and send a clear message to your customers how seriously you take road safety. [+](#)

VOLVO DYNAMIC STEERING

The road ahead is straight. Even when it isn't.

The groundbreaking Volvo Dynamic Steering drastically reduces the effort it takes to steer, making the job easier and safer while minimising the strain on your muscles. It's perfect for construction trucks, where rough terrains, heavy loads and challenging manoeuvring at low speeds are part and parcel of the job. Volvo Dynamic Steering is also available for dual front axles (8x2, 8x4 and 10x4).



How it works.

We have fitted an electrical motor on the steering gear. The motor is controlled – 2,000 times per second – via the truck's electronic control units and produces torque overlay. The torque is progressive and gives more power to the steering when needed, obtaining a predetermined steering feel, independent of load and tyres. This results in a totally different driving experience – reassuringly predictable.



Volvo Dynamic Steering decreases the steering effort by up to 85%.

At high speeds on paved roads, the system swallows potholes and prevents disturbances from reaching the steering wheel.

The steering corrects course deviations, caused by gusts of wind for example.

When the road surface is banked, the steering compensates the slanting and corrects the course.

Reversing is far less demanding, and the steering wheel automatically returns to its neutral position when you're done.

Volvo Dynamic Steering is especially well suited for trucks with multiple rear axles and/or dual front axles.

DRIVER INTERFACE

A world of infotainment at your fingertips.

Easy navigation and improved communication. More efficient fleet management. Volvo Trucks' integrated system for services and infotainment brings it all together on an integrated touch screen – for a safer more comfortable driving experience.

It's easy-to-use and it can be operated directly on the screen, via voice command, and by steering wheel buttons. All the information is where you need it. In one place. Stay connected.



Information is central.

A quick glance at the centre of the speedometer is enough to get key information about gear, I-Shift mode, (adaptive) cruise control, auxiliary brakes and tachometer.

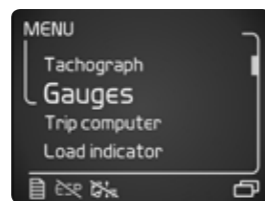

Driver Information Display.

Convenient 4-inch display showing a lot of additional information. Choose what you want to see, using the steering wheel buttons. The customised view allows you to select up to three favourites such as different gauges, driver alert support or load indicator. If an error should occur, the message tells you in clear text what's wrong. No risk of misunderstanding. Available as monochrome or colour display.



Secondary Information Display.

It gives you access to the integrated system for services and infotainment. Navigation, fleet management, communication, increased safety and quality audio entertainment – it's all there on a 7-inch touch screen.

BUILT-IN GPS NAVIGATOR

The Volvo FMX has a fully integrated navigator. Knowing the truck's specification, it can use map data to help you choose a route that suits your axle load and vehicle height. It also integrates nicely with Dynafleet OnBoard, so you can receive exact GPS destinations from the office.

DYNAFLEET ONBOARD

No separate display needed. All information from Volvo's transport management system is integrated in the SID-High.

PHONE

Two phones can be connected via Bluetooth at the same time so you can browse your phone book, talk into the built-in microphone and listen through the speakers.

SOUND SYSTEM

The sound system includes everything you need to enhance your in-cab experience. Access to streaming media services such as Spotify, Deezer and TuneIn. DAB/DAB+ as option. You can connect via USB, AUX or wireless via your smart phone.



THE LOWER FRONT

How can a bumper affect your uptime?

It doesn't matter how skilled you are. On the narrow, dark stretches in the mine or in the gravel pit it's easy to bump into something and damage the truck. Thus, the headlights must be protected and well anchored. Rough surfaces and rocks must not damage the oil pan. The bumpers must withstand rough treatment. And if something does happen, you shouldn't need to bring the truck to the workshop. Just keep on running as if nothing happened. Because uptime is essential.



The sturdy bumper.

It's made of steel, it's in three parts and the attachments are visible and easy to undo. This makes it easy to change the part that is damaged.

So if you run into a pile of rubble, it's no big deal. Perhaps you won't even notice any damage on the bumper. This is because the steel bumper is also covered by a thick polypropylene coat, that will return to its original form if damaged.



The protective front underrun protection.

The complete lower front is made as a box construction. Every part of it interacts, making the construction very sturdy, but at the same time resilient in a collision with a car.

We at Volvo have mistreated this truck in our tests, more than you ever will do. And we are now convinced that this is the sturdiest front in the industry.



The skid plate.

This protecting guard plate under the engine is really worth its name. It is 3 mm thick and it doesn't only protect the engine sump but the hoses and cooler too. Everything that is perishable when driving off road is protected, even when you reverse.

The skid plate has another advantage too; if you drive in a very dusty environment the plate reduces dust vortices under the truck.

A streamlined belly-line.

At least the truck has one.

Compared to traditional leaf suspension, air suspension offers many benefits. It provides a smoother ride, regardless of the road conditions – saving the truck, the cargo and, most importantly, the driver from additional wear. We offer a rear air suspension that is especially developed for construction trucks, offers high ground clearance (at least 300 mm) and is tough enough to handle rough terrain.

FOR DRIVEN FRONT AXLE
The rear air suspension is now also available for Volvo FMX with a driven front axle (4x4, 6x6, 8x6 and 10x6)

BETTER TRACTION AND HIGHER AVERAGE SPEED
Optimised rear-axle pressure on every axle means better traction, thanks to the air suspension. The driver can adjust axle load distribution for better traction if needed. Air suspension gives less vibration into the truck and you will get an improved driving comfort, especially when unloaded. This will also contribute to a higher average speed.

COMFORT AND FLEXIBILITY
Air suspension provides outstanding driving comfort and makes it possible to vary the ground clearance. No parts of the suspension lay outside the rear tyre envelope. This makes it easier to adapt the chassis for applications such as asphalt layers or tippers.

AIR BELLOWS MOUNTED ABOVE THE AXLE
The air bellows are more protected and their positions contribute to the high ground clearance. As do all other components.

STABILISERS IN BOGIE CENTRE
The position of the stabiliser bar results in less torsion forces on the chassis and better roll and tipping stability. It also contributes to the high ground clearance.

PROTECTED BRAKES
Don't worry. No parts of the braking system stick out beneath the rear axle. That's why you can be sure that the truck can handle all obstacles.

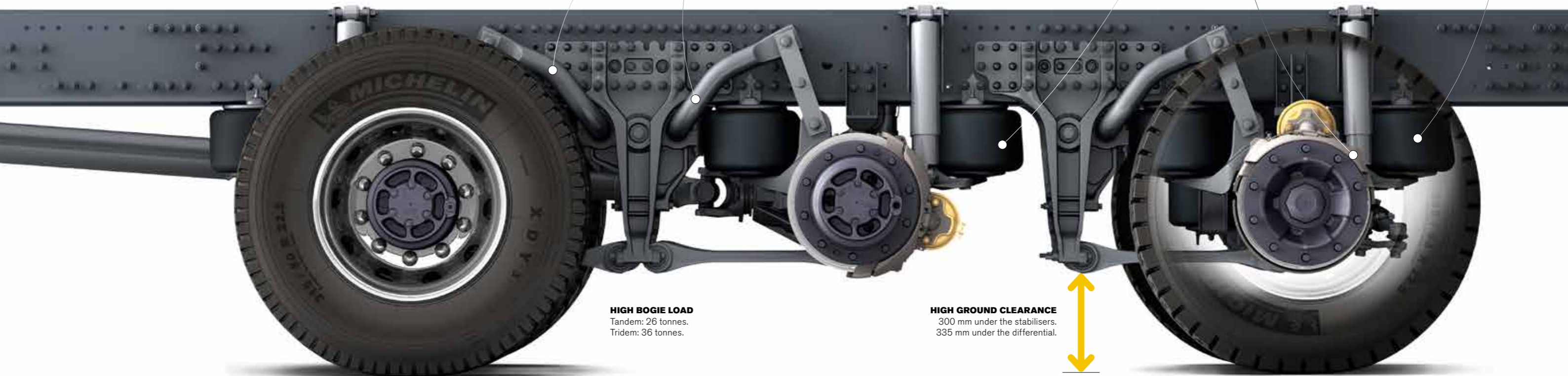

HIGH BOGIE LOAD
Tandem: 26 tonnes.
Tridem: 36 tonnes.

HIGH GROUND CLEARANCE
300 mm under the stabilisers.
335 mm under the differential.

TOWING DEVICE

32 tonnes.

Sometimes it can be more than a little troublesome out there. You simply get stuck. Therefore it's reassuring to know that the Volvo FMX is equipped with a towing device that really pulls its weight.



Take a firm and easy grip.

With one simple grip, you can release the handle to connect a wire or a pull bar to the towing device in the middle of the front. The device has passed tests with lateral pull/push forces up to an astonishing 32 tonnes, at a maximum angle of 15 degrees.



This is why you can trust the towing device.

It is part of a cross member which is made of high-strength steel. The whole assembly is stably mounted in the longitudinal frame members. It provides not only a very strong structure, but it's also a great solution to counteract the eigenfrequency of the chassis, thus enhancing driving comfort.



TANDEM AXLE LIFT

Lower fuel consumption and turning radius?

Just raise the drive axle.

Tandem Axle Lift is a unique feature, allowing your 6x4 or 8x4 to combine the traction and load capacity of four-wheel-drive with the driveability and efficiency of two-wheel-drive – all in one vehicle.



Up to 4% lower fuel consumption when unladen.

Because of the added friction and rolling resistance, drive axles usually consume quite a lot of fuel – all of the time. Not so with Tandem Axle Lift. By disengaging and raising the drive axle when it isn't needed, you can reduce your fuel consumption by as much as up to 4% when unladen. That adds up to a lot of money in the long run.

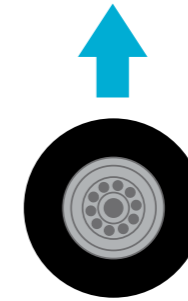

Get a grip.

As long as the axle load limits allow, the axle can be raised to shift all the weight to one drive axle, for better grip and traction. It can even be performed while driving at low speeds.

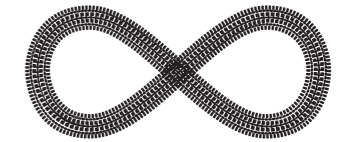

Enjoy better turning radius.

Tandem Axle Lift can effectively convert a 6x4 to a 4x2, or an 8x4 to a 6x2. Just like when raising a dead axle, this significantly improves the manoeuvrability of the truck by shortening the turning radius. In fact, a 6x4 with a wheelbase of 4,6 metres, for example, can reduce its turning radius by over a metre.

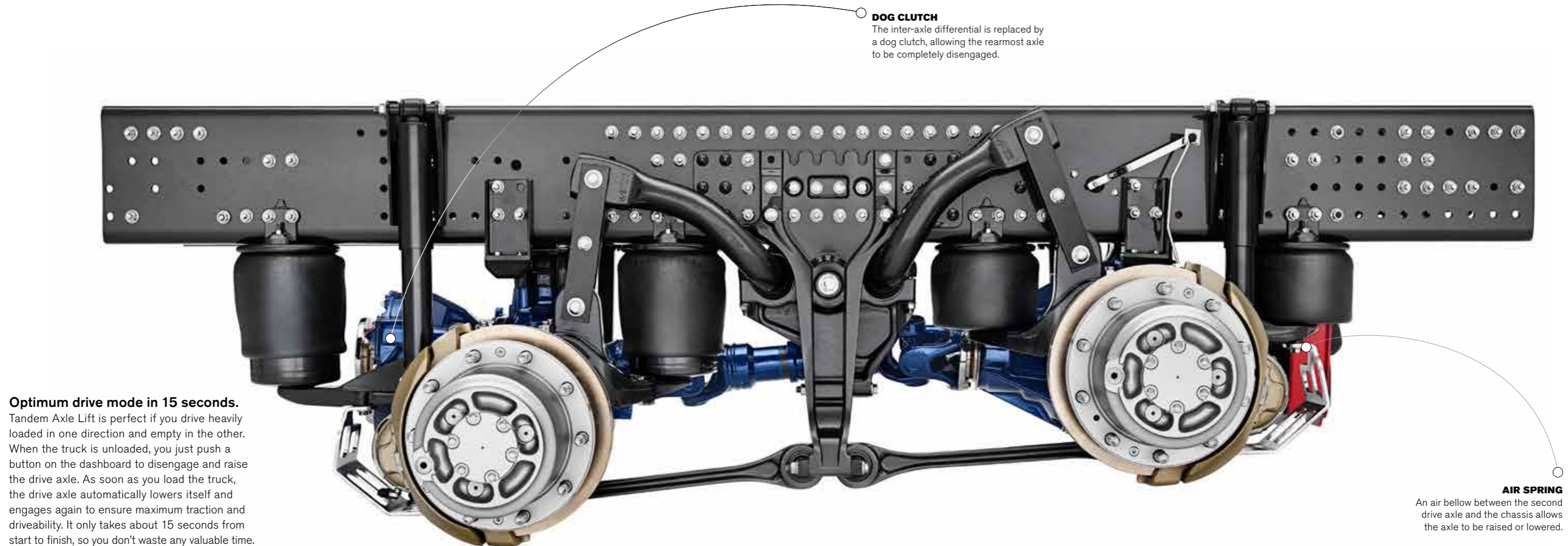

DOG CLUTCH

The inter-axle differential is replaced by a dog clutch, allowing the rearmost axle to be completely disengaged.

Optimum drive mode in 15 seconds.

Tandem Axle Lift is perfect if you drive heavily loaded in one direction and empty in the other. When the truck is unloaded, you just push a button on the dashboard to disengage and raise the drive axle. As soon as you load the truck, the drive axle automatically lowers itself and engages again to ensure maximum traction and driveability. It only takes about 15 seconds from start to finish, so you don't waste any valuable time.

AIR SPRING

An air bellows between the second drive axle and the chassis allows the axle to be raised or lowered.

Prepared to fit your body.

Bodybuilders tend to have a favourite truck and that is Volvo. That's because we've gone great lengths to make things easy for them by preparing the chassis for the superstructure already at the factory. They can avoid unnecessary and costly reconstruction work and that means a shorter stay at the bodybuilder's. Here are some of the features that will make a difference.



Volvo Bodybuilder Instructions.
As soon as you order your Volvo FMX, exact drawings of your truck are available in the intuitive VBI online portal. The bodybuilder can start working while we build the truck, which dramatically shortens lead-times.



Power take-offs for every need.
There's a vast array of PTOs: Engine mounted as well as gearbox mounted, including both clutch-independent and clutch-dependent power take-offs. There is also a wide range of hydraulic pumps even with clutch to save fuel. 🚚



The frame is straight.
Unlike most other trucks, a Volvo features a frame that is completely straight and parallel behind the cab. This makes the bodybuilder's job a whole lot easier.



Staying out of the bodybuilder's way.
We never allow our engineers to place anything above the top of the frame. This area belongs entirely to the bodybuilder – adding a lot of flexibility.

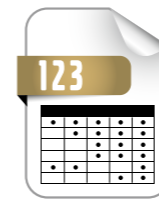

Loads of specification options.
The more possible combinations, the easier a truck is to tailor. That's why the Volvo FMX has more options than ever before when it comes to axle configurations, chassis heights and wheelbases.



A dedicated row of holes.
The frame comes with an upper row of holes that is designated for the superstructure. Since we don't use any rivets here, the bodybuilder can easily attach the equipment.

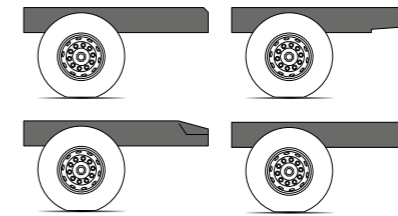

4 different rear end cuts.
We can deliver your FMX from factory with four different rear frame-end cuts: upper (for tippers, hook-lifts and refuse trucks), lower (for centre-axle trailers), bent (for tractors) or straight (for rigids).

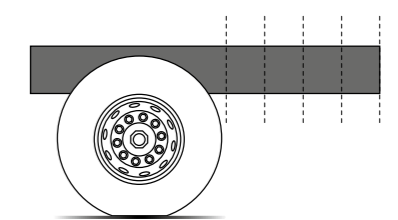

Choose your exact rear overhang.
The rear frame can be factory cut exactly as you need it – in 50 mm increments – to perfectly match your superstructure. Regardless of whether you are in need of an extremely short rear overhang or a longer one.



Rear under-run position.
To widen the rear end options even further, the rear under-run protection can be placed in several different positions.



Two different frame heights.
Choose between a 266 mm and a 300 mm frame depending on the demands of the superstructure.



Body Builder Module.
Makes it easy for the bodybuilder to tap into the truck's electrical system to tailor functions. You can access them conveniently on the flexible dashboard switches and in the Work Remote. 🚚

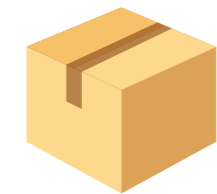

Rigid chassis package.
Options like side under-run protection, bodybuilder attachments, mudguards and LED tail lights are available in a convenient package – easy to order and with high quality.



Attachment brackets.
Volvo FMX can be factory prepared with body attachment brackets, mounted on the frame. Now available not only in the wheel-base area, but also on the rear overhang.



Prepared for a crane.
A low chassis and high axle loads. That is what's on every crane builders wishlist. Volvo FMX comes with both. What's more, we can create a free frame space near the cab, and even deliver your truck with factory-mounted crane plates.

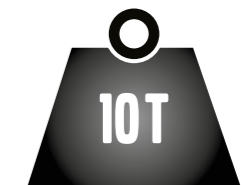

A wide range of reinforcements.
Some heavy applications put a lot of pressure on the frame. But don't worry. For the Volvo FMX you have a wide range of choices of inner-liners, providing all the reinforcement you may need.

DRIVER SUPPORT SYSTEMS

Even a first-rate driver can need some extra support on the road.

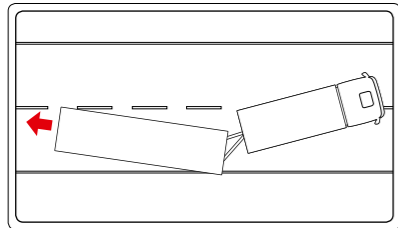

Stretch Brake.

In certain situations, such as turning or driving downhill on a slippery road, the trailer risks catching up with the truck, creating a hazardous jack-knife effect. The Stretch Brake is designed to stop that from happening. By pulse braking the trailer, the vehicle combination is stretched, and the danger reduced. The system can be automatically activated in risky situations, at speeds up to 50 km/h. Stretch Brake is now available for rigid trucks as well as tractors.

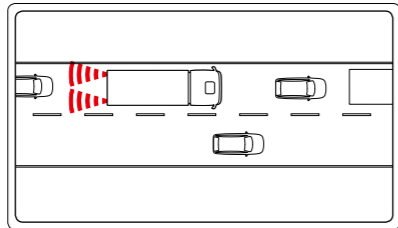

Emergency brake light.

If you slam on the brakes, the brake lights flash rapidly to alert the vehicles behind you. An effective way of avoiding rear-end collisions, which can lead to major pile-ups and cause fatal injuries. 🚚

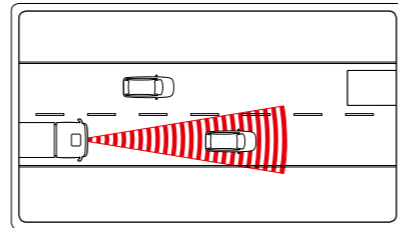

Adaptive Cruise Control, collision warning and emergency brake.

Follow the traffic rhythm without effort. The radar-based Adaptive Cruise Control (ACC) keeps a safe distance to the vehicle in front by controlling the accelerator and all available brakes. If there's a risk of collision, warning lights are projected on the windscreen – and if an impact is imminent, the automatic emergency brake quickly comes to your assistance.

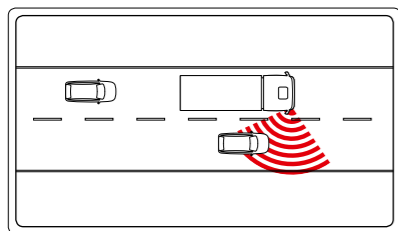

Lane Changing Support.

The blind-spot area on the passenger side can easily hide other road users. Lane Changing Support is equipped with a radar that checks this area when you activate the turn signal. If the area's not clear, you are notified by a sound and a flashing icon by the mirror.

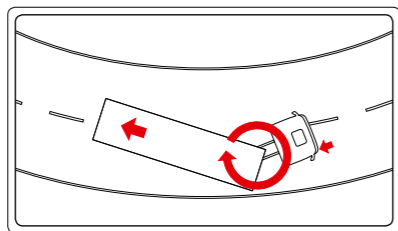

Electronic Stability Program.

The Electronic Stability Program (ESP) applies the brakes individually on each wheel. This provides stability for the entire vehicle combination, thus counteracting jack-knifing, roll over and trailer swing. ESP is available for tractors and rigid trucks with two or three axles. 🚚

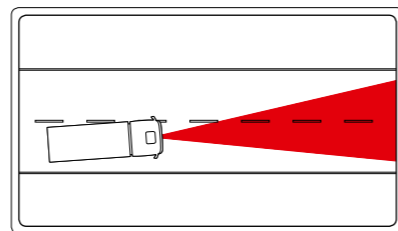

Driver Alert Support.

Driver Alert Support is an intelligent system that tracks your driving behaviour, complementing the camera-based Lane Keeping Support, which now comes as standard. If it differs from normal and indicates tiredness, you are alerted by a signal and a message in the display, advising you to take a break.

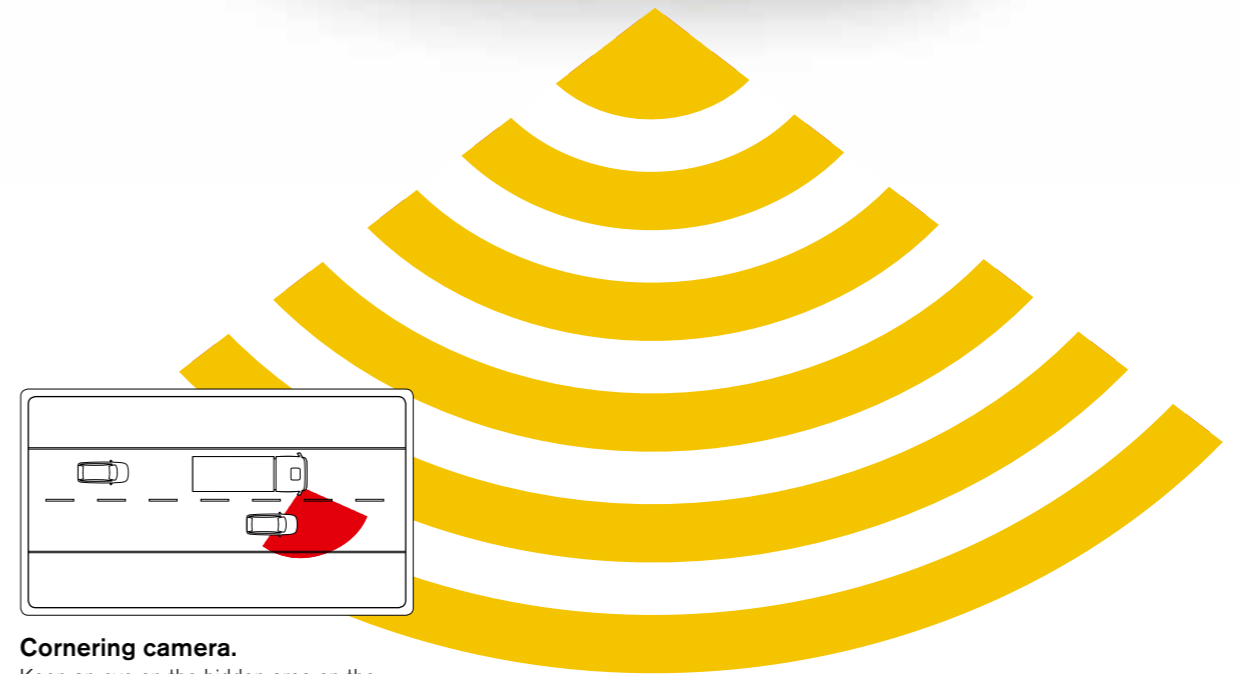

Cornering camera.

Keep an eye on the hidden area on the passenger side of the truck. The cornering camera is activated when using the side turn indicator and displays the side view in the Secondary Information Display.

Pure power and torque.

Without jeopardising fuel efficiency.

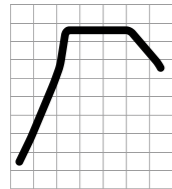

The Volvo torque curve. You'll feel it in the pedal.

Excellent torque at low revs. An extremely wide max torque range. Peak torque meets peak power. Volvo's leadership in diesel-engine technology is clearly visible once you start comparing engine curves. You'll experience fast acceleration, excellent pulling power, comfortable low-speed handling and, not least, a fuel-efficient and pleasurable ride at cruising speed.



A wide engine range. Pick yours.

The engine range for Volvo FMX comprises many different power ratings: both 11-litre (D11) and 13-litre (D13). You can rest assured there's always one that suits your transport operations.



Fuel efficiency built-in.

The fast and precise EMS-controlled injection. The optimised combustion chamber geometry. The high gas-fill ratio. We could go on listing what makes Volvo engines hard to beat when it comes to fuel economy. Your bottom line will reap the benefits. And so will the environment.



Volvo Engine Brake.

Minimise wear on the brake pedal. If you want to maintain a high average speed without compromising safety or fuel economy, you need a powerful engine brake. That's why Volvo Engine Brake (VEB), available on the D11, is so widely appreciated. And on the D13, you have access to our patented VEB+, absorbing up to a massive 375 kW (510 hp), thanks to the unique camshaft design with four rocker arms.

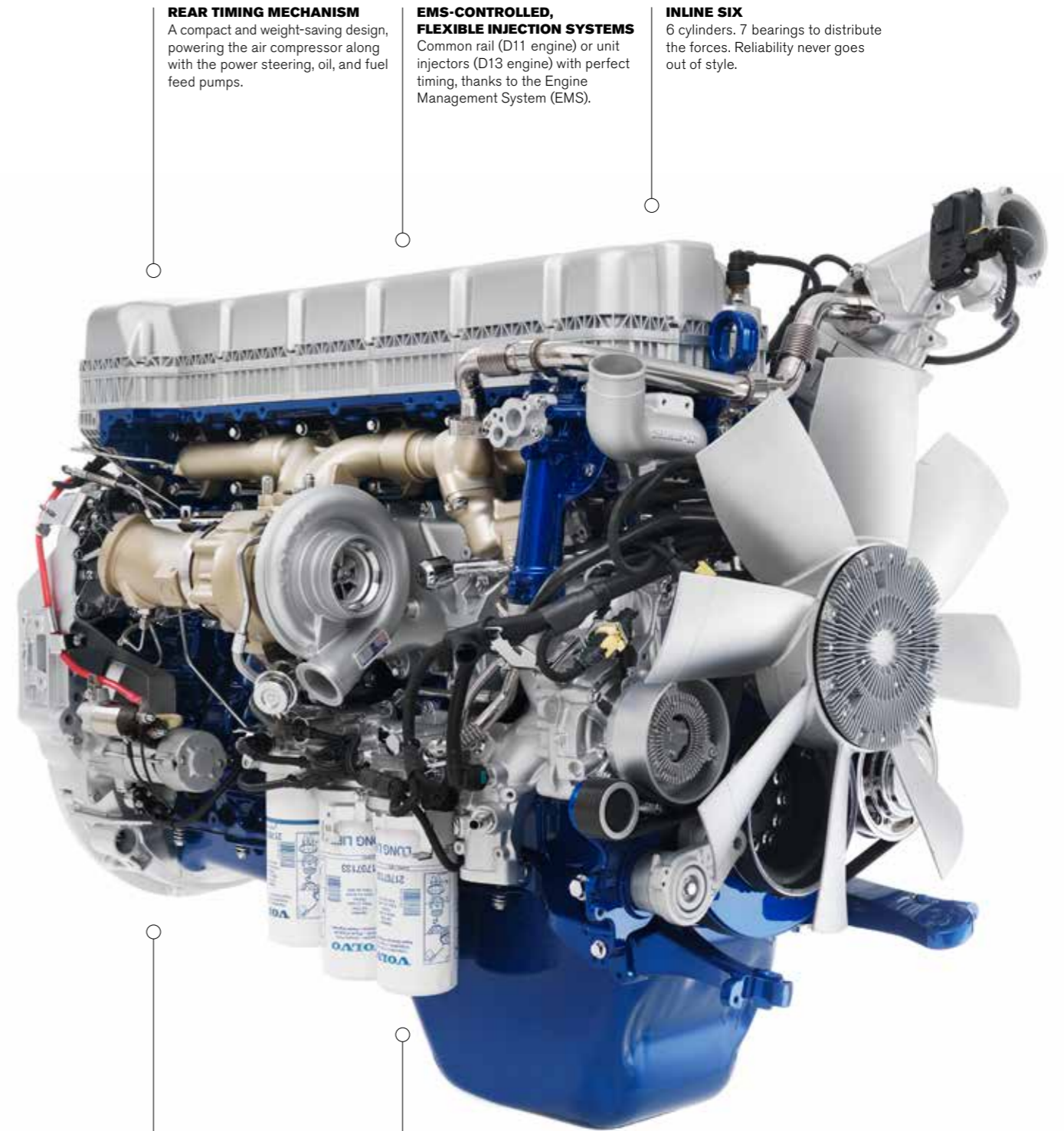

REAR TIMING MECHANISM

A compact and weight-saving design, powering the air compressor along with the power steering, oil, and fuel feed pumps.

EMS-CONTROLLED, FLEXIBLE INJECTION SYSTEMS

Common rail (D11 engine) or unit injectors (D13 engine) with perfect timing, thanks to the Engine Management System (EMS).

INLINE SIX

6 cylinders. 7 bearings to distribute the forces. Reliability never goes out of style.

HYDRAULIC PUMPS WITH CLUTCHES

The range of engine-mounted hydraulic pumps includes two de clutchable ones.

CLOSED CRANKCASE VENTILATION

Recycles the crankcase gases, for improved air quality around the vehicle.

Take the curves in your stride.

If you drive a lot on decent roads and a large percentage unladen (which most construction trucks do), the air-suspended tridem is an excellent option. The three-axle bogie improves close-quarter manoeuvrability and offers the possibility to raise one of the axles (or even two) for lower fuel consumption and increased traction.

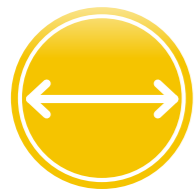

**Steer tightly.
Ride comfortably.**

The tridem bogie comes with a choice of a tag axle (behind the drive axles) or a pusher axle (in front of the drive axles), or even both (if you drive an 8x2). Since the axles can be hydraulically steered, the turning radius is much tighter than it is on a truck with dual front axles, making it easy to manoeuvre challenging routes. Plus, the air suspension makes for a comfortable ride, especially when unladen.



Less weight, higher payload.

The tridem is now available in a light-weight variant. By removing the inner-liner and reducing the weight of several other components, we've managed to cut 150-200 kilograms. This allows you to increase your payload and improve your fuel economy.



Raise the axle and save fuel.

If you want to reduce your fuel consumption, you want to minimise your rolling resistance when driving on the road. This is where tridem comes to your help. When a dead axle isn't needed to distribute the weight, it's automatically raised. By doing so, fuel consumption and tyre wear can be minimised. To avoid overload, the axle is then automatically lowered as soon as you load the truck.



TIGHT TURNING CIRCLES
Tridem gives the truck a tighter turning radius, saving time when navigating narrow spaces.

HEADLIGHTS

Enlightening news.

Now you can really see the light in the tunnel. The powerful headlights give a strong, wide, smooth light with an extremely long range making construction assignments more relaxed and much safer.

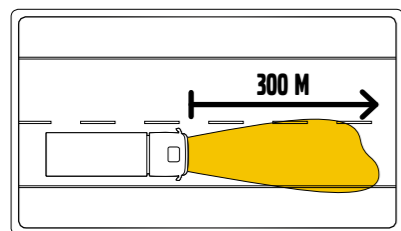

Leading main beam.

While driving in the dark, the Volvo FMX is a particularly good friend. The headlights produce a powerful beam, providing you with an early view on what is happening down the road. And, just as important, other road users will see you.



On at dusk and off at dawn. Automatically.

The headlights now come with automatic switching as an option. Just like on a car, a sensor detects when the dipped beam needs to be activated and does this automatically for you. And as soon as the light conditions allow, it automatically switches back to daytime running lights. 



Bi-Xenon.

Equip the headlights with Bi-Xenon to experience a new level of brightness. They also offer longer service life compared with regular halogen lamps.

SIDE TURN INDICATOR

MAIN BEAM

DIPPED BEAM

TURN INDICATOR

UNIQUE DAYTIME RUNNING LIGHT
LED strips, forming a unique V-shape, shows that a Volvo is approaching. 

HEADLAMP PROTECTION
No one likes a one-eyed truck – especially not the driver. Choose from two different headlight protectors: one approved for on-road use, and one for demanding off-road conditions. 

We'll support you all the way.

And on your way.

SUPPORTING YOUR TRUCK

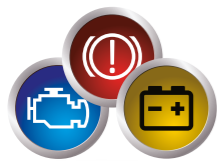

Connected Service Planning. One step ahead.

Thanks to the Telematics Gateway, the workshop can access information such as engine data, mileage, fuel consumption, diagnostic trouble codes, driving conditions and status of crucial components (brake pads, clutch, battery and air dryer etc.). This means we can alert you in time, before you risk an unplanned stop. But most importantly, we're always perfectly prepared when you enter the workshop. So you'll be back on the road before you know it.

Need help? Just push the button.

An unplanned stop out in the middle of nowhere? Volvo Action Service with On Call is just a button push away. It automatically connects you to an operator who speaks your language (the truck checks the nationality of the card in the digital tachograph). Once connected, service is both fast and accurate, because they already know your chassis ID, position and possible diagnostic trouble codes.

SUPPORTING YOUR DAILY WORK



Driver training. Working in Construction.

Working in Construction is a unique Driver Development course offered for the Volvo FMX. It is a one-day classroom course, covering personal safety routines and ways to work efficiently and eliminate risks. Also included are off-road driving techniques to avoid accidents or getting stuck – and what to do if it should happen. Vehicle features are also covered – those connected to off-road driving, different superstructures and power take-off usage. Furthermore, you will learn how to utilise the full potential of systems such as I-Shift and Automatic Traction Control.



Dynafleet app.

This app makes it a lot easier to work as a driver, and hopefully more fun. You can follow up your fuel-efficiency score and ranking, alongside your driver times and points of interest on a map. You can also compare your performance with those of your colleagues. This app is available for a smartphone or a tablet.



Fuel advice.

Gives you access to our fuel management coaches – true experts in reducing fuel consumption. Every month, they send you enhanced fuel reports with personalised advice on how to improve. You can get more advice via the dedicated help desk, or log on to the toolbox to find hands-on tips and inspiration.



Work Remote.

The electronically controlled suspension (ECS) improves driving comfort and helps in making sure the cargo travels safely. ECS4 is the latest version and offers even more possibilities, with the Work Remote as the most prominent example. You now have perfect control of the vehicle height, equipment such as PTOs and functions on the superstructure. The Work Remote also has a load indicator. You have full control, regardless of whether you're sitting behind the wheel or walking around the truck.

SUPPORTING YOUR BUSINESS



Volvo Premium Lease.

Sometimes it might be smarter not to own your truck. Volvo Premium Lease gives you the opportunity to choose a solution that suits your needs, because it may include funding, road taxes, insurance, repair and maintenance, and even replacement tyres. You will greatly benefit from fixed and predictable costs for accurate budgeting, improved cash flow and reduced capital outlay.

5-AXLE CONFIGURATIONS

An excellent factory option: add an extra axle.

Want to transport heavy loads? No problem. The Volvo FMX offer includes the five-axle 10x4 configuration as well as the 10x6 with a driven front axle.

For a wide range of jobs.

The five-axle Volvo FMX is equipped with dual front axles and an air-suspended tri-axle bogie (with a tag axle), allowing a maximum gross vehicle weight of 56 tonnes. This makes it well suited for a wide range of applications such as concrete mixers, fire trucks, sky lifts and large cranes. And if you're into heavy haulage, you might be able to take on bigger assignments and avoid costly overweight permits. Drive in very rough terrain? Opt for the 10x6 with a driven front axle.



Ready to go.

Without delays or extra costs.

We now offer trucks with five axles directly from our factory. This way, you get a Volvo FMX that is ready for efficient, heavy transportation from day one. In other words, you don't have to contact an external supplier for costly and time-consuming retrofitting of an extra axle. Moreover, we also deliver your truck with a full vehicle type approval.

Full Volvo support.

From day one.

Since we deliver a complete truck to you, it not only comes with Volvo quality through and through. You also get full Volvo warranty and Volvo support. This means that you always have a truck in top condition, and that we quickly help you in all kinds of situations to keep you going and stay efficient.

SPECIFICATIONS

Tailoring your Volvo FMX.

This is just a hint of all the choices you have when tailoring your Volvo FMX to your needs. The full specifications and all possible options are available at www.volvotrucks.com or at your Volvo dealer.

Cabs

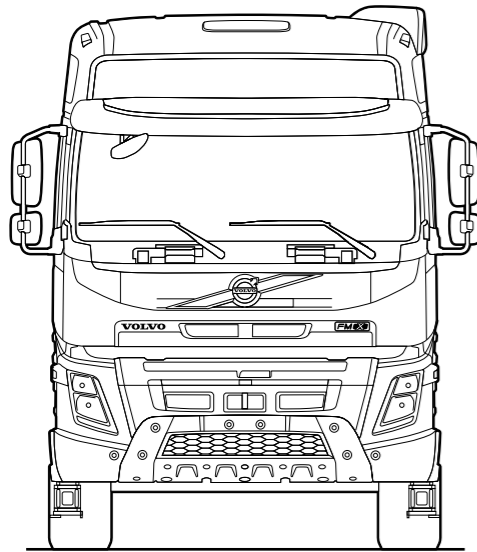

Day cab



Sleeper cab



Globetrotter cab

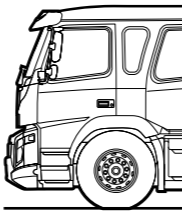

Crew cab

Tractor axle configurations

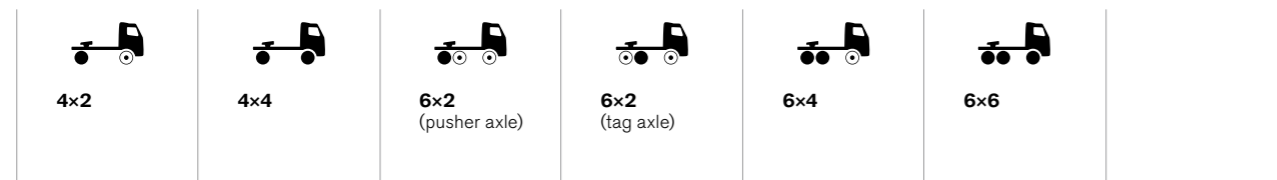

Rigid axle configurations

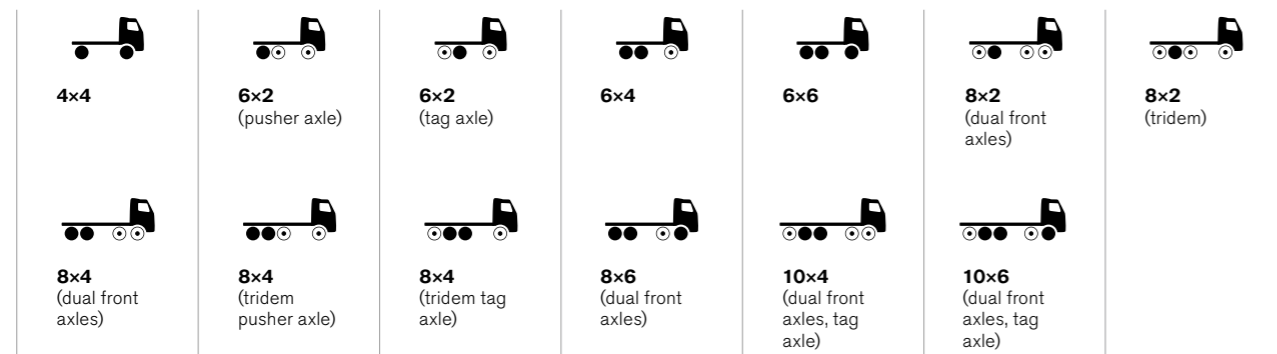

● = Drive axle.
○ = Dead axle (tag, pusher or front axle).

Engines

11 LITRE	Max power	Max torque
EURO 3		
D11A330 (243 kW)	330 hp at 1400–1950 r/min	1650 Nm at 1000–1300 r/min
D11A370 (273 kW)	370 hp at 1600–1900 r/min	1770 Nm at 1000–1400 r/min
D11A430 (317 kW)	430 hp at 1800–1900 r/min	1970 Nm at 1100–1400 r/min

EURO 4		
D11C330 (243 kW)	330 hp at 1600–1900 r/min	1600 Nm at 950–1400 r/min
D11C370 (272 kW)	370 hp at 1600–1900 r/min	1750 Nm at 950–1400 r/min
D11C410 (302 kW)	410 hp at 1600–1900 r/min	1950 Nm at 950–1400 r/min
D11C450 (332 kW)	450 hp at 1600–1900 r/min	2150 Nm at 950–1400 r/min

EURO 5		
D11C330 (243 kW)	330 hp at 1600–1900 r/min	1600 Nm at 950–1400 r/min
D11C370 (272 kW)	370 hp at 1600–1900 r/min	1750 Nm at 950–1400 r/min
D11C410 (302 kW)	410 hp at 1600–1900 r/min	1950 Nm at 950–1400 r/min
D11C450 (332 kW)	450 hp at 1600–1900 r/min	2150 Nm at 950–1400 r/min

13 LITRE	Max power	Max torque
EURO 3		
D13A400 (294 kW)	400 hp at 1400–1800 r/min	2000 Nm at 1050–1400 r/min
D13A440 (324 kW)	440 hp at 1050–1400 r/min	2200 Nm at 1050–1400 r/min
D13A480 (353 kW)	480 hp at 1400–1800 r/min	2400 Nm at 1050–1400 r/min
D13A520 (382 kW)	520 hp at 1400–1800 r/min	2500 Nm at 1050–1450 r/min

EURO 4		
D13A420 (309 kW)	420 hp at 1400–1900 r/min	2100 Nm at 1000–1400 r/min
D13A460 (338 kW)	460 hp at 1400–1900 r/min	2300 Nm at 1000–1400 r/min
D13A500 (368 kW)	500 hp at 1400–1900 r/min	2500 Nm at 1050–1400 r/min

EURO 5		
D13C420 (309 kW)	420 hp at 1400–1900 r/min	2100 Nm at 1000–1400 r/min
D13C460 (338 kW)	460 hp at 1400–1900 r/min	2300 Nm at 1000–1400 r/min
D13C500 (368 kW)	500 hp at 1400–1900 r/min	2500 Nm at 1050–1400 r/min
D13C540 (397 kW)	540 hp at 1450–1900 r/min	2600 Nm at 1050–1450 r/min

Gearboxes

I-SHIFT

12-speed splitter and range gearbox with automated gearchanging system. The version with crawler gears facilitates easy operation with GCW up to 325 tonnes.

Type	Top gear	Engine torque (Nm)	GCW approval (tonnes)
AT2412F	Direct	2400	44
AT2612F	Direct	2600	60
ATO2612F	Overdrive	2600	60

POWERTRONIC

Fully automatic power-shift transmission with torque converter and oil cooler. Changes gears without power loss.

Type	Top gear	Engine torque (Nm)	GCW approval (tonnes)
PT2106	Direct	2100	44
PT2606	Direct	2600	60

MANUAL GEARBOXES

14-speed splitter and range manual gearbox with two crawler gears. Short and distinct gear settings with low gearchanging forces.

Type	Top gear	Engine torque (Nm)	GCW approval (tonnes)
VT2214B	Direct	2200	100
VT02214B	Overdrive	2200	100
VT2514B	Direct	2500	100
VT02514B	Overdrive	2500	100
VT2814B	Direct	2800	100
VT02814B	Direct	2800	100

Here's a small selection of specifications – but there are more to choose from.

Ask your Volvo dealer or visit www.volvotrucks.com to learn more.

ACCESSORIES

Make it your truck.

The Volvo FMX is one of the most well equipped trucks in the world. But to tailor it for your particular transport assignments and for your personal needs, there's also a wide range of accessories to choose from. It's all about making the truck more efficient for the work you do. And don't forget that they are all developed and tested by Volvo Trucks for Volvo trucks to make sure they all bring what you expect from a Volvo product. Hey, we've even crash tested the coffee maker!

Here's a small selection of accessories – but there are tonnes more to choose from. Ask your Volvo dealer or visit www.volvotrucks.com to learn more about accessories.



Exterior vision camera



Portable warning and working light



Air blow gun



Roof arch



Cradle plate for phone



Exterior water tank



Red seat belt



Headlamp protector



Alcolock

Some of the equipment shown or mentioned may only be available as options or accessories and may vary from one country to another in accordance with local legislation. Your Volvo dealer will be happy to provide you with more detailed information. Colours may vary somewhat owing to the limitations of the printing process. We reserve the right to alter product specifications without prior notification.

VOLVO

Volvo Truck Corporation
volvotrucks.com