



Volvo Trucks. Driving Progress

VOLVO FE

PRODUCT GUIDE - EURO 3-5



Your flexible working partner.

Ideal for delivering refrigerated food yet adaptable as a concrete mixer. Or a refuse transporter. The Volvo FE more than lives up to its reputation as a multi-purpose vehicle which delivers excellent driveability combined with first-class productivity. Designed with city and regional distribution in mind, it is easy to load and unload, and offers the driver a comfortable, spacious environment in which to work. Focusing on simple manoeuvrability, increased safety and generous visibility, the Volvo FE does not sacrifice any of Volvo Trucks' legendary power and performance. Plus, with Volvo as your working partner, you can take advantage of a wide range of flexible services, safe in the knowledge that you have chosen a transport solution of the highest class.

This is why:

1 Easy to own, easy to drive.

A truck that offers you maximum flexibility when and where you need it. With unrivalled all-round capabilities and ease of driving, you are free to concentrate on your daily tasks, letting us take the strain.

2 Comfort.

Designed for long days in the driver's seat. Whatever your professional commitments, the Volvo FE delivers optimum comfort and ergonomics, making it a place you will want to call home.

3 Safety.

At Volvo we pride ourselves in focusing on your safety. Our trucks are fitted with the latest, most developed systems to ensure not only your health and wellbeing, but also to prevent accidents and to mitigate the resulting consequences should an accident occur.

4 Peace of mind.

We ensure that our Volvo services keep you on the road, offering the potential to maximise your productivity without taking any unnecessary risks.

5 Power and engineering.

Regardless of the engine size you choose, the Volvo FE will provide ample power and performance. And electrical systems, transmission and technology to match. Read more on [page 8](#).

6 Easy to adapt.

Three cab sizes, great choice of engine output levels and a chassis that's easy to tailor for different needs. Build your Volvo FE to suit your operations.



First-class distribution. At any temperature.

In a competitive business like distribution, it is comforting to have a reliable vehicle fleet behind you. Particularly when you are transporting and delivering delicate products such as frozen goods. With its powerful 7-litre, 6-cylinder engine with its generous power and torque output, the Volvo FE delivers top performance and is perfect for distribution work. Lightweight front and rear axles create the possibility for even more payload. And excellent visibility facilitates driving in urban environments. Three cab equipment packages are available: Distribution, Distribution+ and Vocational.



Part of the Volvo family.

The distinctive new design, featuring the Volvo iron mark, is a sign of quality on the road. We believe that your business can benefit from a positive partnership with Volvo. Our heritage of designing trucks of the highest calibre is respected worldwide. Welcome to the family.



Tail lift.

The tail lift makes the work much easier and efficient. You can order your truck factory prepared for the tail lift with all the electrical wiring, a switch on the dashboard and a new icon on the instrument cluster.



Headlights.

When you are out on the road making deliveries, the Volvo FE's powerful, adjustable headlights and fog lamps ensure good visibility, even in poor conditions. Furthermore, their distinctive design ensures that everyone knows there is a Volvo approaching.

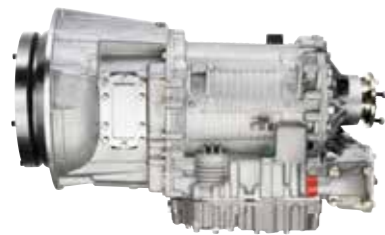

Automatic transmission – take the weight off your left foot.

Driving the Volvo FE with automatic transmission means you can forget the clutch pedal. Easy operation, excellent starting properties, 6 gears and smooth gear changes – so that you can concentrate on the traffic.



With superior all-round vision.

The Volvo FE allows you to appreciate the world around your cab. The size and strategic placement of the mirrors deliver the finest possible all-round visibility, while auxiliary windows provide you with a perfect view of the area close to your vehicle.



Don't fret, don't worry.

At Volvo Trucks, we believe that you should be free to focus on what is important to you in your professional life. You need valuable uptime from your truck – we deliver. You can increase the productivity of your business by employing our flexible range of services. We also work towards lowering the total cost of ownership of your vehicle. All things considered, the Volvo FE represents an extremely profitable enterprise for you and your business.



Flexible contracts tailored to your needs.

With a selection of Volvo Service Contracts, you can take advantage of the ideal transport solution. Our contracts offer you the freedom to decide on the maintenance and repair of your vehicle's operation, when required. This flexibility helps keep your productivity at a maximum. Specific superstructures can also be included in your contract.



Seeing is believing. And performing.

In a Volvo FE, you'll always have a good feel for your surroundings. The placement and size of the mirrors together with the sightline through the front windshield will provide you with the best possible visibility. Add to that the auxiliary windows and you're left with the best possible conditions for managing the inner-city hustle.



Your truck – the way you want it.

At Volvo we fit our trucks to your requirements. By letting us know what you need from your Volvo FE, we can then prepare the truck directly from the factory, with the necessary body attachments and electrical connections for the bodybuilder. This process significantly shortens lead times when building the superstructure, which means that you receive exactly the truck you want for your business – fast.



Your vehicle is secure.

An advanced remote-controlled alarm system makes the Volvo FE an enemy of the thief. Easily activated in the event of unwelcome guests trying to open the doors or disturb the vehicle, it offers you peace of mind when you are elsewhere.



Simple manoeuvring – wherever you are.

The Volvo FE is easy to manoeuvre even in the most congested spaces. It is a vehicle that allows for easy steering and smooth acceleration, as well as providing an array of instruments to help you navigate every situation.



Because driving should be a pleasure.

When constructing the instrument cluster and dashboard of the Volvo FE, we felt it was important to focus on common-sense simplicity. The placing of the dashboard's gauges and instruments is designed to be operated with a single glance, offering the best possible ergonomics and allowing you to enjoy a smooth, intuitive drive, however busy the roads are.



The complex system that makes it easier.

Every function on the truck can be simply activated from the driver's seat. A modern, comprehensive electrical system permits easy control and regulation, while applications can be introduced on specification.



Volvo Premium Lease.

If it suits you to lease your distribution vehicle or vehicle fleet, a Volvo Premium Lease is available for a monthly fee. A comprehensive package is available, including everything except fuel and driver costs. Let your business run smoothly. Read more about Volvo services on **page 25**.

Power and performance on demand.

Flexibility, power, quick response – and kinder to the environment. Volvo FE engines ensure a performance which makes the vehicle an essential professional tool for city and regional distribution. The range is now extended with engines for alternative fuels and a extra power and torque strong 340 hp* engine for demanding operations. Incorporating the very latest in machine technology, the Volvo FE represents the perfect long-term investment when you need to ensure maximum uptime and productivity for your business.

STARTING HELP

Also called muddy site, this helps you to maintain constant revs in your selected gear. This option is particularly effective when starting on slippery road surfaces.

CLOSED CRANKCASE VENTILATION

With the closed crankcase ventilation system, you'll be able to avoid oil loss, loss that might contaminate areas where oil spillage is forbidden. This is something especially important for foodstuff distribution or other segments where environmental demands are particularly strict.

ENGINE BRAKE AND EXHAUST BRAKE

The engine brake saves the wheel brakes and extends the lifetime of both the brake pads and the brake discs. In the Volvo FE, there are two powerful engine-braking systems to choose between – exhaust brake on its own or exhaust brake in combination with compression brake.

STRICT REGULATIONS

The Volvo engine range has been constructed and adapted to comply with the European emission standards as defined by a series of European Union directives (Euro 3, 4 and 5). Through these directives the levels of nitrogen oxides (NO_x), total hydrocarbon (THC), non-methane hydrocarbons (NMHC), carbon monoxide (CO) and particulate matter (PM) are regulated.

The Volvo D7 range meet all the legal prerequisites presenting the user, as well as the surroundings, with an environmentally friendly engine that still manages to offer power and performance of the highest class.

VARIABLE GEOMETRY TURBO

Improved truck performance at low speed is achieved through the use of a variable geometry turbo. This allows the effective aspect ratio of the engine's turbo to be altered and contributes to the flat torque output and super-fast response.

TORQUE

The D7 engine will secure wide, flat torque output and lightning-quick response, even at low rpm:s. The torque is generous, meaning minimised gearchanging. See tables on **page 27**.

ADBLUE

AdBlue* is added from a separate tank, lowering exhaust emissions. AdBlue accounts for 5–6% of the Volvo FE engine's diesel consumption.

QUICK RESPONSE

The D7 engine is a top performer in any situation. Where tight manoeuvring is required – in heavy urban traffic for example – you can rely on a lightning-fast response everytime.

COMMON RAIL INJECTION SYSTEM

The high-pressure electronic injection is provided by common rail, with a maximum pressure of 2,000 bar.

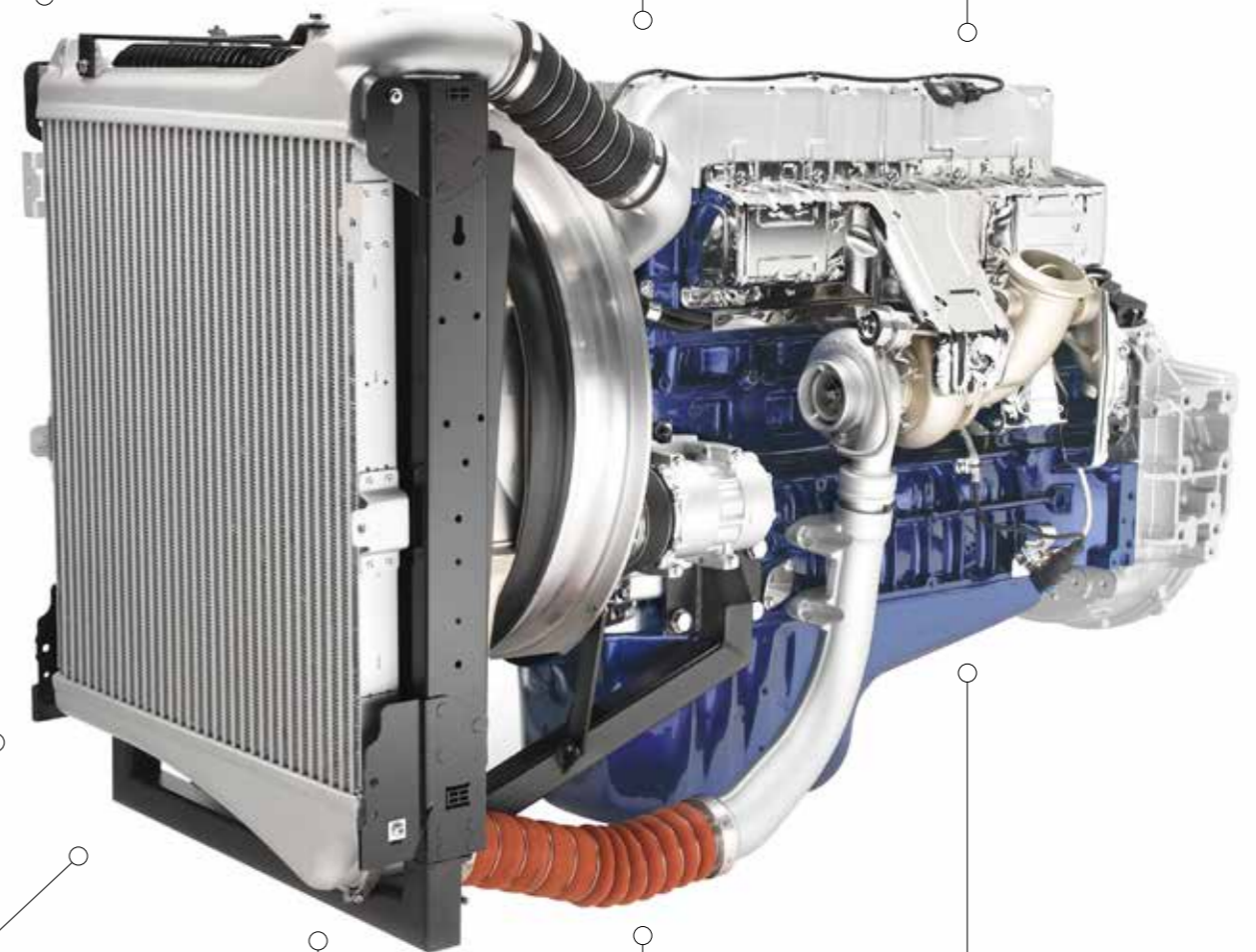

AFTER-TREATMENT**

Volvo Trucks' after-treatment solution makes sure the driveability is maintained, while optimising exhaust-gas temperature and NO_x levels for efficient after-treatment. In addition to the SCR catalyst, the after-treatment system has been equipped with a diesel oxidation catalyst, a diesel particulate filter and auxiliary heat injection – all contained within the same muffler. The result is an engine with excellent power and performance that complies with the regulations, taking good care of our environment and our future.

POWER TAKE-OFF

The power take-offs on the Volvo FE provide power for running an auxiliary application or the vehicle's own load-handling equipment.

ENGINE IDLE SHUTDOWN

When the engine is left on idling for a defined period of time, the engine switches off to save fuel and reduce emissions. Good for your bottom line and the environment.

SIX CYLINDERS

The Volvo D7 engine is a six-cylinder, 7 litre powerful diesel engine. Ideal for city-distribution trucks. The D7 is one of the most reliable six-cylinder engines on the market. And with the choice of power output it is optimised for any particular transport assignment.

* Available on Euro 5 markets.

** Available on Euro 4, Euro 5 and Euro 6 markets

THE FLEXIBLE CHASSIS

A framework for success.

When adapting the chassis of the Volvo FE, our engineers set their imaginations to work. A flexible model was the collective vision, one that could be fitted to almost any assignment a truck could undertake. They then developed a sturdy, durable chassis with foldable side underrun protection which, although light, could bear heavy loads and could be easily customised. The choice of a 9 tonnes front axle made the truck even more agile. Now you can put the results of their endeavour to the test.

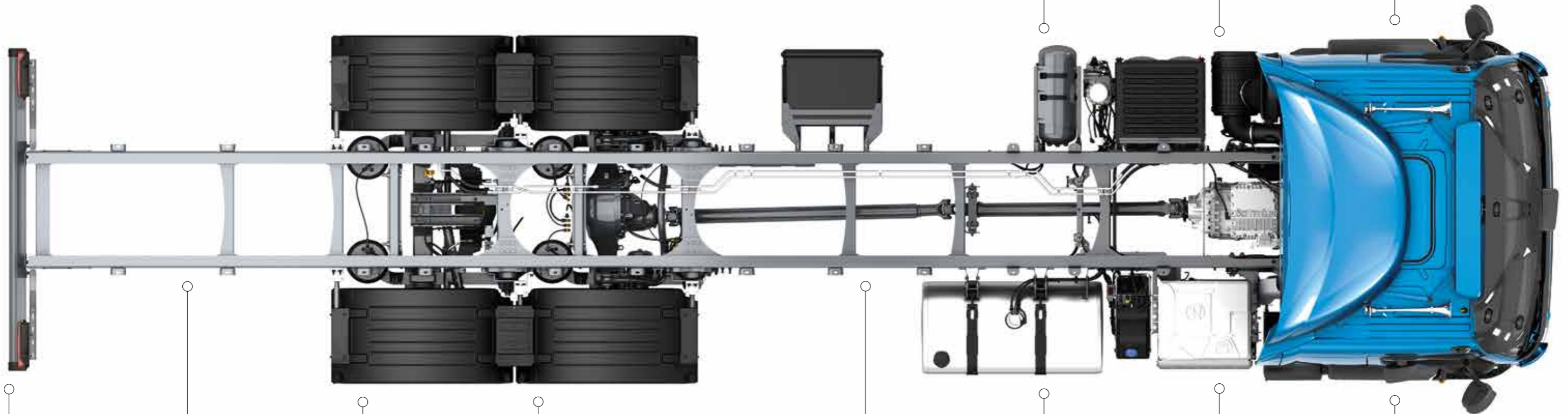

TAILOR-MADE, PREPARED OR STANDARD

The Volvo FE chassis can be ordered with a standard layout. But if you really want to make it easy for the bodybuilder you can order it with the preparation kit or even completely adapted to fit your specific needs. Thanks to the Volvo Bodybuilder Instructions (VBI system), the lead-times for the bodybuilder are shortened and you'll get your perfect truck, with the perfect superstructure, adapted to your specific business operations, in the shortest time possible.

SPECIAL APPLICATIONS

For specific applications such as refuse transporters, tankers and cranes, the chassis can be specially adapted. Fuel tanks and/or AdBlue tanks are repositioned in order to accommodate the application in question.

TRAILING AXLES

There are two types of trailing axles on the FE chassis. The TA-FIXED axle is a fixed tag axle with single or double wheels. The TA-HYDRS is a hydraulically steered tag axle with single wheels only.

REAR AXLES

Four different rear axles are available in various combinations. Load capacity varies from 13 to 23 tonnes.

FRAME HEIGHT

There are two variants of frame height (FRAME266 and FRAME300) with a frame thickness of 7 mm and 8 mm respectively.

FRAME INNER LINER

On three-axle vehicles there is, as standard, an inner liner to reinforce the area around the rear axles' installation.

FUEL TANKS

Plastic, steel or aluminium fuel tanks with varying capacities of between 160 and 630 litres can be stipulated, according to truck specifications and special requirements.

TOOLBOXES

The Volvo FE comes equipped with two separate toolboxes – a smaller version with 55 litres in volume and a larger 125-litre model. These are perfect for keeping load security straps or other equipment.

WHEELBASE

There is a choice of wheelbases on the Volvo FE range, between 3,200 and 6,800 mm depending on the vehicle model and axle configuration.

SUSPENSION

There is a choice of suspension on the Volvo FE for both front and rear axles. These are dependent on the axle load. Air and leaf suspension are available in a variety of combinations.

AIR SUSPENSION

The Electronic Control System (ECS) can be used to control the air suspension levelling, via switches on the dashboard or a control box. This results in easy, fast loading, regardless of the height of the loading ramp.

FRONT AXLES

Maintenance-free front axles are available on the chassis of the Volvo FE, with maximum load capacity of 7.1 to 9.0 tonnes.



The truck that delivers a clean sweep.

When choosing the right truck for your business demands, there is always the temptation to prioritise or compromise on certain details. With the Volvo FE you don't need to.

We fit the superstructure that suits your exact requirements. The FE 6x2 rigid with its low noise level, impressively low emissions, unrivalled all-round visibility and easy manoeuvring make it the perfect choice for refuse transporting operations. Frequent stops and starts are aided by a generous D7, 6-cylinder, 7-litre engine, performing up to 340 hp, combined with automatic transmission, while the low cab has a convenient entry with anti-slip steps. However, with an interior this comfortable, you might not want to get out too often.

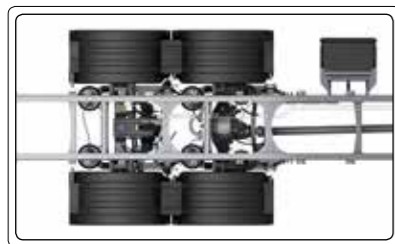

Rear axle. Carrying a heavy rear load means trusting the suspension on your truck. The light-weight rear axle of the Volvo FE supports weights of 13 tonnes and the air suspension ensures the smoothest possible journey.



Automatic transmission. Stopping and starting your vehicle as frequently as you do when collecting refuse, it's reassuring to know that you have the assistance of an automatic gearchanging system. Using this type of transmission means that you can simply concentrate on driving your vehicle from one stopping point to the next.



Instep. Ideal for frequent stops, when entering and leaving your vehicle. Anti-slip steps and accessible handholds make your task easier, even in adverse weather conditions. Optional lighting on the doors is ideal when working on dark mornings or at dusk.



CAB INTERIOR

Step into a more comfortable working day.

When your daily routine requires entering and exiting your vehicle frequently, a convenient, ergonomically designed instep is a must. Once inside, a spacious interior with well-appointed features makes your truck a relaxed space that is a real pleasure to work in. Take a look around the Volvo FE interior – adapted with your comfort in mind.



Spacious cab sizes.

There are three different spacious cab options with the Volvo FE. The day cab is the most compact of the three while the comfort cab can be equipped with or without bed. The larger sleeper cab always comes with a bed, offering ample space for rest and relaxation. Learn more on [page 26](#).



Cab suspension.

A smooth drive is guaranteed by the Volvo FE's state-of-the-art cab suspension. There is a mechanical cab suspension, with coiled springs and shock absorbers at both front and rear, while full air cab suspension features bellows at both front and rear.



Even more generous storage space.

Look around the cab and you will find an abundance of space to store your items. Storage compartments in the dashboard. In the doors. Above your head. Between the seats. Plus, you have the option of adding yet more storage units if you so wish.



All-new seats.

New ergonomic seats are a key feature of the latest Volvo FE interior, with improved anchoring, integrated head-restraint and seat belt. New upholstery material provides added resistance to dirt. Both the driver and the passenger seats can be adjusted to suit your needs.



Low interior noise.

Maximum sound isolation means that the Volvo FE can be driven in a relaxed environment with engine and tyre noise minimised.



Ergonomic thinking.

When planning a cab's layout, we consider what is most important to you, the driver. It's called ergonomic thinking. Placing the instruments and gearshift strategically, so that you can reach and control everything without straining. The controls you use most often are placed close to the steering wheel, making your job a great deal easier.



Instep.

Optional stairwell lighting is available in the form of a lamp in the door's lower frame. Accessible handholds and two anti-slip steps make regular entry and exit of your vehicle easy.



Audio options.

Choose between several audio packages. They can include RDS radio, USB connection, Bluetooth for streaming music and connection dual phones and hands-free as well as DAB preparation.



Steering wheel.

The steering wheel can be adjusted to your favoured position and has a diameter of either 460 or 500 mm.



DIN compartments.

Above the windscreen there are two storage units, as well as four DIN compartments. The DIN compartments are intended for items such as a communication radio, extra storage and tachograph.



Climate control options.

A climate unit keeps the cab temperature at the right level – with or without the use of air conditioning.



Dashboard and centre consol layout.

The dashboard and cluster layout makes it easy to access the vital information you will need. Speed, rpm, fuel and oil levels are all instantly visible, helping you plan your journey with ease.

CAB EXTERIOR

We took something good and made it better.



When designing and building our range of trucks, we believe in each member of the Volvo family having its own distinct personality. The Volvo FE stands out from the crowd in this respect. It is a vehicle that radiates a particular confidence, and a balanced, sleek exterior marks out its territory as the highest quality vehicle in its specific field. A recent new design builds on this unique personality, achieving a thoroughly modern look. Trademark V-shaped LED lamps are one of its most recognisable characteristics on approach. The Volvo FE – all things considered, a mark of distinction.



Part of our premium range.

The Volvo FE is part of Volvo's premium truck range – from the mighty Volvo FH16 to the Volvo FMX, a rugged beast of a construction vehicle. No matter your assignment, we have the truck to match.



Feel proud to drive a Volvo.

The prestigious iron mark on the Volvo FE is now placed high on the front of the vehicle, closer to you, the driver.



Optional roof hatch.

A roof hatch is available – either in glass or metal – which is controlled either manually or electrically.



Front grille.

The front grille features a honeycomb mesh pattern that allows for more efficient air-flow, facilitating improved cooling of the engine.

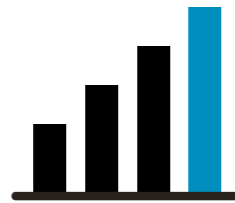

A comprehensive solution.

With maximum adaptability and excellent driveability, the Volvo FE represents a perfect choice when looking to optimise productivity in your business. We make sure you receive the exact vehicle you need. Whether your business is construction, distribution or refuse handling, the Volvo FE is here to do the job.



Air Deflectors.

Air deflectors assist in decreasing resistance and additional wind deflector panels reduce fuel consumption even more.



SAFETY

Developed with your safety in mind.

At Volvo we pride ourselves in taking your safety seriously. This is part of our heritage and is built into our core values. It is naturally a key reason behind the constant technological improvements we are making to our vehicles. The Volvo FE features excellent visibility and improved in-cab safety, as well as an innovative protection system. This not only increases your own safety, but also the safety of those around you on the road.



Reinforced cab.

The entire cab has been reinforced in order to provide a strong safety space should an accident happen. The doors, the rear wall, the roof and the floor, every part of the cab has been reinforced. This makes the cab safer when it comes to cargo shifting, collision or even fire. And of course the cab has passed all Volvo's collision and crash tests which are significantly harder than the law requires.



Integrated seatbelts.

The seatbelts have been integrated in the comfort and standard seats and have an excellent impact resistance. The seatbelts are also available in red, thus making it easy for passers-by to confirm their use.



Reinforced seats and seat anchoring.

The seats are of course safely anchored to the floor, and the anchoring has been specially reinforced in order to provide maximum safety.



Front and Rear Underrun Protection Systems.

Other road users are protected by the Front Underrun Protection (FUP), as well as by the Rear Underrun Protection (RUP), which prevents smaller vehicles from becoming wedged under the truck in the event of a collision.



Extra equipment.

You can always specify any extra safety equipment you want in your cab. Warning vests, fire extinguishers and first aid kits are all available.



ENHANCED ALL-ROUND VISIBILITY

When driving in an urban environment it is vital that you are able to get the total picture of your surroundings at all times. With electrically controlled, optionally heated exterior mirrors, you will be in complete control of what you see.

A manual option is also available. Tinted, solar managed glass is available as option. This reduces the heating up of the cabin due to sun.

EXCELLENT FORWARD VISIBILITY

The windscreen is large and has a low bottom edge. This means an excellent forward view also right in front of the truck.

EXTRA WINDOWS

Extra windows in the doors and side panels are also available. These are particularly useful when driving in confined spaces, while a rear-view window lets you keep an eye on your precious cargo.

THREE-PIECE BUMPER CONCEPT

The Volvo FE's innovative bumper concept incorporates steel corners that provide excellent impact resistance. It is also easy to change a single part if it becomes damaged, leading to lower repair costs.

Building a brighter future.

When your business is construction, you need to maintain a flexible vehicle fleet. The Volvo FE serves this purpose perfectly. It works equally well as a tipper as it does as a concrete mixer. When fitted with a small hooklifter, it functions admirably as a crane. Robust yet agile, the Volvo FE is the perfect all-rounder, highly suited to removing obstacles, transporting materials or helping to construct new urban developments. With excellent manoeuvrability, it's at home in any situation.



Stay clean.

Protects the vehicle's original upholstery. And make cleaning easier. The seat covers (option) are especially designed for Volvo in two colours, providing a perfect fit and design. Complies with Volvo's stringent requirements for resistance to fire and wear.



Volvo Bodybuilder Instructions.

When you order your new Volvo FE, the bodybuilder logs into Volvo Bodybuilder Instructions and can see the exact specifications of your truck. Work commences on building your truck, using drawings created on the system. This intuitive technology has the positive effect of hugely reducing lead times.



New seats.

The Volvo FE is fitted with all-new ergonomic seats which provide maximum comfort when spending long days behind the wheel. The seats can be tilted and adjusted to suit your needs and the woven textile upholstery is dirt resistant – ideal when driving in a dusty environment.



Ergonomics.

The instrument cluster and dashboard of the Volvo FE has been intuitively planned to offer the driver the best possible ergonomics when managing them. The dashboard's gauges are placed to give a perfect overview of operations with a single glance. The controls you need most are the most accessible – simple.



Sleeper cab.

The Volvo FE has three separate cab options – the day cab, the comfort cab, and the sleeper cab. The sleeper is the most spacious model, perfect for longer assignments when there's need of resting during the working day. Read more about the roomy cab interiors on **pages 14**.



Choose the best gear for your surroundings.

Deciding the correct transmission can be difficult. You must take various circumstances into account – the load capacity of your vehicle, your current surroundings, the transport assignment you are undertaking. At Volvo Trucks, we deliver solutions that make it possible for you to find the best alternative everytime.

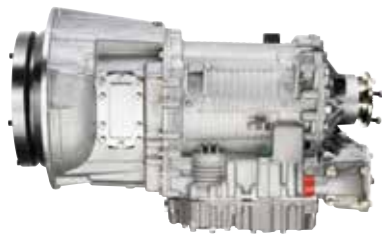

Auto.
For applications where the assignments demand frequent starts and stops without interruption in power delivery, there is an automatic transmission. It offers maximum comfort for the driver.

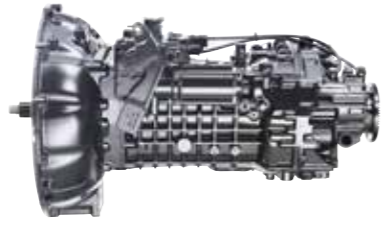

Manual.
When opting for a manual shift transmission you have the option of six or nine speeds. The six-speed transmission is suited for inner-city driving while the nine-speed is adapted for applications with high demands on startability and performance.



Power take-offs.
Power take-off is a feature of all transmissions, offering the possibility to provide power to specific attachments or machinery. The Volvo FE features a variety of power take-offs.



Disc Brakes.
The Volvo FE features pneumatic brakes with lightweight discs at both front and rear in order to aid smooth braking.



Clutches.
The functional push-type clutches on the Volvo FE vary from size 395 mm to 430 mm and feature one single plate.



Engine brake.
The engine brake saves the wheel brakes and extends the lifetime of both the brake pads and the brake discs. In the Volvo FE there are two powerful engine-braking systems to choose between – exhaust brake on its own or exhaust brake in combination with compression brake.



The complete transport solution.

Buying a company vehicle is an important long-term investment. It should be a careful, considered choice, based on many different factors. Once you have made this decision, you should be free to concentrate on your business. When you purchase a Volvo FE, we let you do precisely that.

Being part of the Volvo family means being able to take advantage of our comprehensive range of solutions. Whatever your requirements, you can be sure there is a package that suits you perfectly.



Tailored Service Contract Solutions.

The Volvo Service Contract goes a long way towards securing the necessary uptime for a profitable enterprise. Maintenance and repairs, pro-active planning, monitoring of critical parts and service of your vehicle only when absolutely required. A tailored service contract solution works together to safeguard your business productivity and offer you peace of mind. Choose between the Gold, Silver and Blue service contracts.



Dynafleet.

Dynafleet is a fleet management system that helps you with vehicle, driver and transport handling. The system gives you the necessary information, making it possible for you to have full control of your vehicles' location and status as well as provide you with advice on what areas could be improved. The fuel efficiency of individual drivers, driver hours, locations and arrival times – all are easily monitored. The Dynafleet system is also available as a convenient smartphone and tablet app.



Every drop counts.

Volvo Trucks' philosophy when it comes to sustainable fuel savings is a part of Volvo's holistic approach to optimal energy usage and minimised environmental impact. With relatively small measures, fuel consumption can be significantly lowered, sparing both the environment and the customer's wallet. The campaign encompasses driver training and technical innovations as well as accessories and services such as choice of equipment, vehicle maintenance, traffic planning systems and analysis. Small details, such as a correct wheel alignment and appropriate choice of tyres can lead to significant fuel savings.

Read more about Every drop counts on www.volvotrucks.com/everydropcounts



Fuel Advice.

In order to reduce the fuel consumption and provide you with effective tools to minimise your fuel costs, Volvo offers the Fuel Advice service that consists of personal fuel coaching, an easy-to-use toolbox and support. Thanks to Fuel Advice your saving potential could be as much as 5%, making a real positive impact on both your overall fuel economy and your environmental footprint.



Volvo Premium Lease.

The Volvo Premium Lease offers a trouble-free ownership, which allows you to concentrate fully on your core business. With a fixed, predictable monthly cost for financing, service and repair, as well as insurance, you'll experience minimal risk and disruption to your business. Furthermore you'll enjoy the advantage of accurate budgeting, improved cash flow and reduced capital outlay. With a Premium Lease, the truck is not shown as an asset on your balance sheet which preserves your credit for other engagements. A Volvo Premium Lease will help your business run even more smoothly and without effort.



Volvo insurance.

Volvo insurance offers a thoroughly flexible and comprehensive solution for outstanding insurance coverage. The solutions can, of course, be tailored to suit your individual business needs. The three basic types of insurance are:
Third part liability: covers you against damages to third parties caused by you.
Casco insurance: covers damages on your own equipment, non-related to third party, like fire, theft and vandalism.
Gap insurance: covers the gap between outstanding finance amounts and vehicle value in case of total loss. Gap is available for finance contracts with Volvo Financial Services.

The insurance is provided by your Volvo dealer, making your truck even easier to own, saving time, effort – and money.



Driver development.

By taking part of the Volvo driver development, you hone skills and increase both awareness and knowledge of using your Volvo FE. Efficient driving will lead to reduced risks of accidents, increased overall safety, lower fuel consumption and increased productivity. And you'll always be able to get the most out of your investment, achieving big savings through small changes.

SPECIFICATIONS

Tailoring your Volvo FE.

This is just a hint of all the choices you have when tailoring your Volvo FE to your needs. The full specifications and all possible options are available at www.volvotrucks.com or at your Volvo dealer.

Cabs

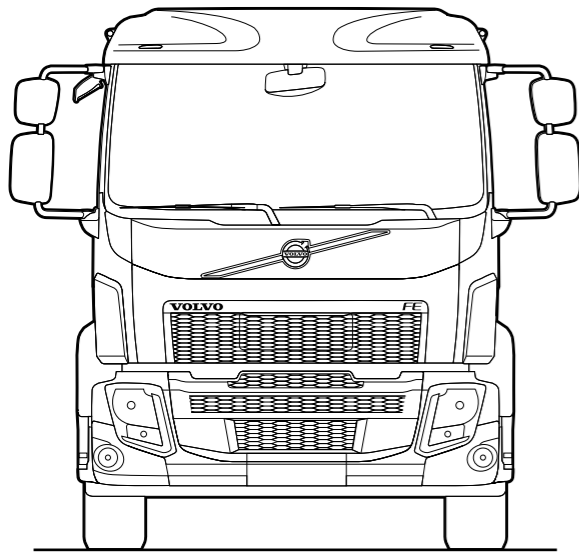

Day cab



Comfort cab

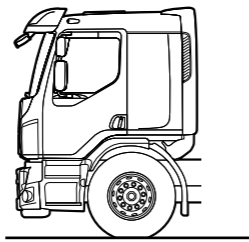

Sleeper cab

Rigid axle configurations



4x2
Medium
High



6x2
Medium
High



6x4
High

● = Drive axle.
⊙ = Dead axle (tag, pusher or front axle).

Engines

EURO 5	Max power	Max torque
D7F240 (177 kW)	240 hp at 2,300 r/min	940 Nm at 1,200–1,800 r/min
D7F260 (191 kW)	260 hp at 2,300 r/min	1,010 Nm at 1,200–1,800 r/min
D7F300 (221 kW)	300 hp at 2,100 r/min	1,160 Nm at 1,200–1,800 r/min
D7F340 (250 kW)	340 hp at 2,300 r/min	1,300 Nm at 1,200–1,700 r/min

EURO 3, 4	Max power	Max torque
D7E240 (177 kW)	240 hp at 2,300 r/min	920 Nm at 1,200–1,700 r/min
D7E280 (206 kW)	280 hp at 2,300 r/min	1,050 Nm at 1,200–1,700 r/min
D7E320 (235 kW)	320 hp at 2,300 r/min	1,200 Nm at 1,200–1,700 r/min

Gearboxes

MANUAL GEARBOXES

The manual gearboxes are operated with servo assistance. The short gear lever, which is integrated into the instrument panel, is vibration-free and gear lever movement is short and crisp. The gearboxes can be specified with a power take-off.

Type	Top gear	Engine torque (Nm)	GCW approval (tonnes)
ZTO1006	6	1,050	32
ZTO1109	9	1,200	36
STO1309	9	1,300	44

AUTOMATIC GEARBOX

The automatic transmission presents excellent starting properties and smooth gear changes that cover the entire speed range. The gearbox is operated via push buttons in the instrument panel. It can be specified with power take-off.

Type	Top gear	Engine torque (Nm)	GCW approval (tonnes)
AL306	6	1,500	32

Here's a small selection of specifications – but there are more to choose from. Ask your Volvo dealer or visit www.volvotrucks.com to learn more.

ACCESSORIES

Make it your truck.

The Volvo FE is one of the most well equipped trucks in the world. But to tailor it for your particular transport assignments and for your personal needs, there's also a wide range of accessories to choose from. It's all about making the truck more efficient for the work you do. And don't forget that they are all developed and tested by Volvo Trucks for Volvo trucks to make sure they all bring what you expect from a Volvo product. Hey, we've even crash tested the coffee maker!

Here's a small selection of accessories – but there are tonnes more to choose from. Ask your Volvo dealer or visit www.volvotrucks.com to learn more about accessories.



Seat covers



Battery reconditioner



Engine Idle Shutdown software



Fire extinguisher



Audio package



Battery charger

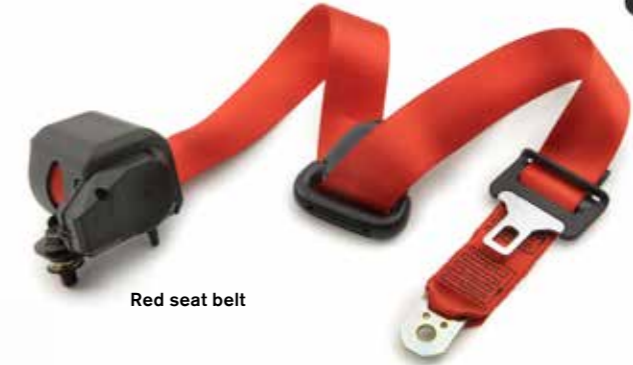

Red seat belt



Portable warning and working light with batteries



Plastic wheel cover



Rubber mat

Some of the equipment shown or mentioned may only be available as options or accessories and may vary from one country to another in accordance with local legislation. Your Volvo dealer will be happy to provide you with more detailed information. Colours may vary somewhat owing to the limitations of the printing process. We reserve the right to alter product specifications without prior notification.

VOLVO

Volvo Truck Corporation
volvotrucks.com